



<b>Elevating and Amusement Devices Safety Program</b>	Ref. No.: 278-19
<b>ADVISORY</b>	Date: May 15, 2019

**Subject:** Otis Brake Lever for 130, 131, 139 and 156 series Gearless Machines  
**Distribution:** Posted on TSSA website

---

1. **Incident Investigation**

- 1.1 The Technical Standard and Safety Authority completed an investigation of an **elevator unintended motion incident** where an elevator moved in the up direction and away from the floor with both the elevator “car doors” and “landing doors” open. The elevator finally stopped when it reached the top of the hoistway.
- 1.2 Investigation determined that wear in the **brake lever arm** may prevent the brake arm from fully lifting the brake shoes, which could result in brake lining wear and ultimately compromise the brake’s holding efficiency.
- 1.3 This installation also had brake monitoring switches, however it appears that wear in the **brake lever arm** prevented proper functioning of the brake switches and the incident investigation found the brake switches were by-passed.
- 1.4 The root cause of the brake failure was improper or lack of brake maintenance by the elevator contractor.

2. **Advisory**

- 2.1 This advisory intends to share awareness related to:
- the incident investigation findings
  - the need for brake examination & maintenance check points
  - a critical brake maintenance check point on these specific Machine models
  - an Otis Legacy Product Advice document complete with ‘tips’ and part numbers. (extracts of this document are attached)

## Gearless Machine Brake Lever

ID 2019-01  
Page 1  
January 1, 2019

---

Otis has determined that the ductile iron brake lever used on 130, 131, 139 and 156 series gearless machines is subject to wear, typically over a period of years, at the point it contacts the hardened lift pion. The wear may compound in arrangements using an O-ring isolated lift pin. This wear is a maintenance issue that will be evident to the mechanic conducting the required inspections and maintenance. The wear may be more pronounced on units installed to comply with B44/CEN where each brake shoe is required to hold 125% of the duty load.



Figure 1: Brake Lever with Wear

Regular maintenance as required by A17.1/B44 8.6.4.6 should include examination of bearing surfaces for accumulated wear. Excessive wear at this point may prevent the brake arm from fully lifting the shoe with the potential to compromise the brake's holding efficiency.

If the wear exceeds 1/16th inch (1.6 mm) in depth, the brake lever should be replaced. Replacement ductile iron brake levers available from Unitec Parts have been redesigned and are now furnished with a hardened steel bearing button at the point of impact. Brake levers should be replaced in pairs.

---

### Gearless Machine Brake Lever

ID 2019-01  
Page 2  
January 1, 2019



Figure 2: Brake Lever (AAA288AAG2) with Hardened Bearing Button

Due to the additional height of the hardened bearing button, the brake lift will need to be re-adjusted at bolt "3" in the image below

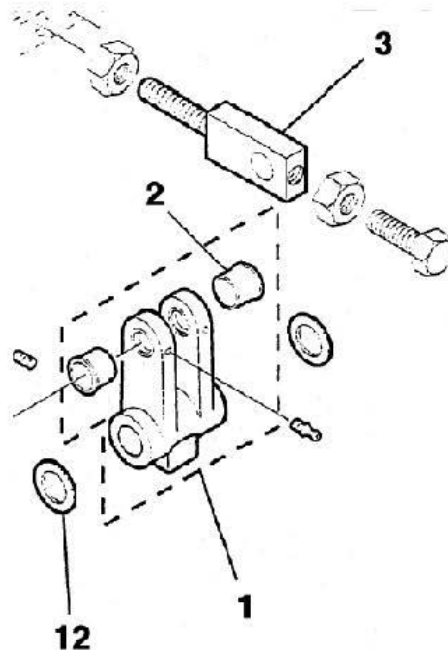

Figure 3: Brake Lift Geometry Bushed Lift Pin

### Gearless Machine Brake Lever

ID 2019-01  
Page 3  
January 1, 2019

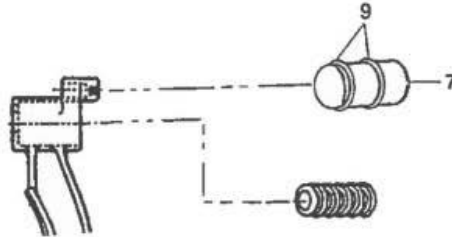

Figure 4: O-Ring Isolated Contact Pin

NOTE 1: Otis Gearless Machine Series 130, 131, 139 and 156 are visually very similar and share many components but are not identical. Be sure to have the information from the machine vintage tag (Figure 5) available when ordering brake parts.

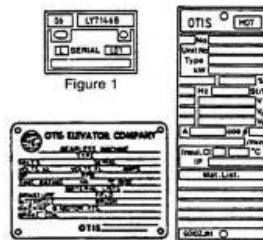

Figure 5: Typical Machine Data Plate

NOTE 2: Brake lever B288GG1 used on the 130HT arrangement is cast steel and will not include the bearing button.

Gearless Machine Brake Lever

ID 2019-01  
Page 4  
January 1, 2019

---

**Appendix A: Related Part Numbers**

The following table lists all part numbers this document mentions.

**Table 1: Related Part Numbers**

<b>Description</b>	<b>Part Number</b>
Brake Lever (1) with Bearing	B288GG1
Bearing (2)	209A6
Brake Lever	JXA288HX1 use AAA288AAG4
Brake Lever (1) with Bearing	AAA288AAG2
Brake Lever (1) with Bearing	AAA288AAG4
Brake Lever	B288HX4 use AAA288AAG2
Brake Lever	JXB288HX2 use AAA288AAG2
O-Ring (9)	172JK1
Contact Pin (7)	81BN2 (with O-Rings)
Bronze Washer (12)	128AL2